

THIS DRAWING IS UNPUBLISHED. RELEASED FOR PUBLICATION
 © COPYRIGHT BY TYCO ELECTRONICS CORPORATION. ALL RIGHTS RESERVED.

LOC		DIST		REVISIONS			
P	LTR	DESCRIPTION		DATE	DWN	APVD	
	C	REVISED PER ECO-08-006965		24MAR08	HMR	CC	

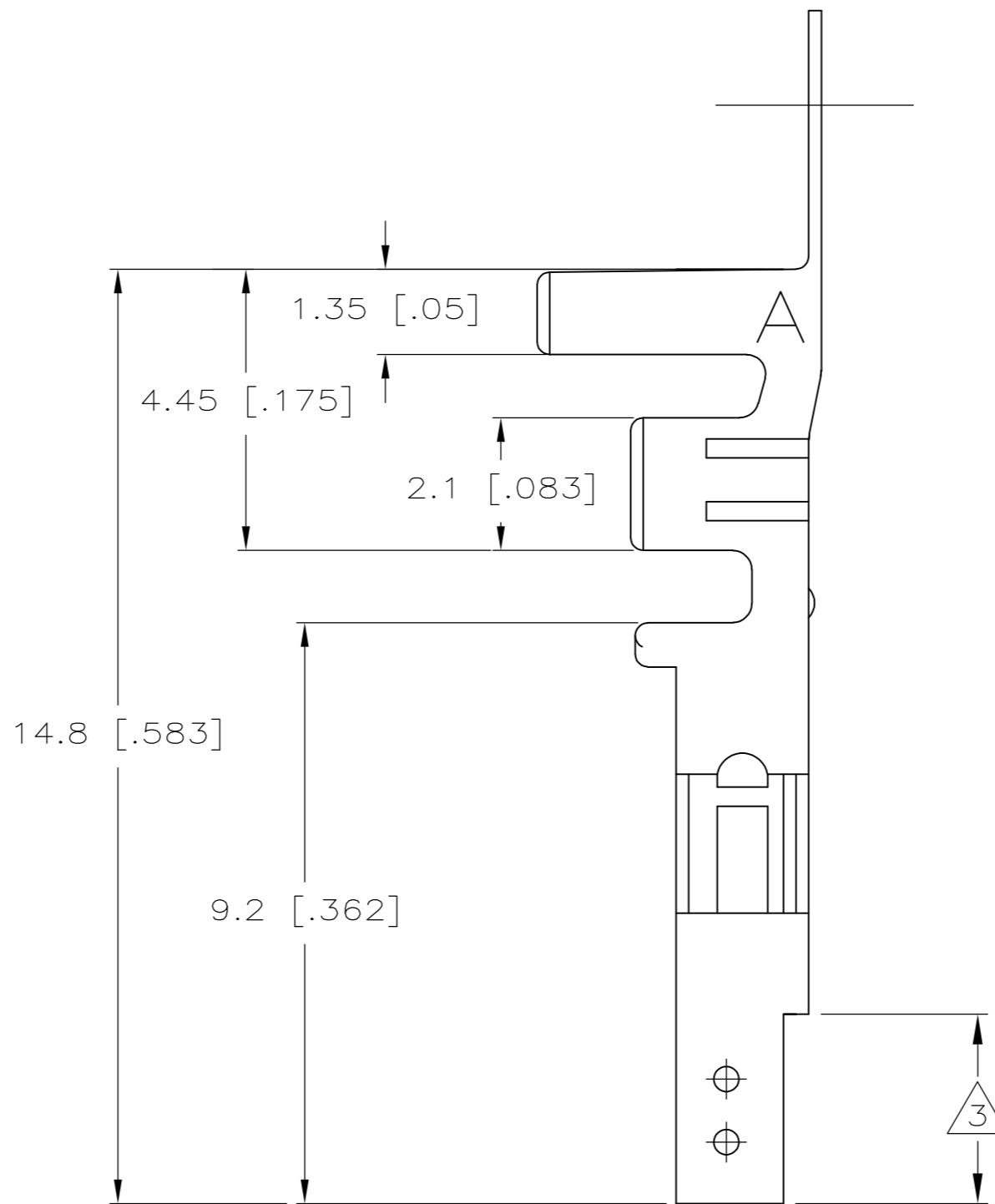

- 1 WIRE RANGE: 1.31mm² (16 AWG).
- 2 INSULATION RANGE 3.10 [.122] MAXIMUM DIAMETER
- 3 FINISH: 0.76µm MINIMUM GOLD OVER 1.27µm MINIMUM NICKEL REQUIRED ON INNER SURFACE, PERMITTED ON OUTER SURFACE.
- 4 FINISH: 2.54µm MINIMUM TIN ON ALL SURFACES IN THIS AREA.

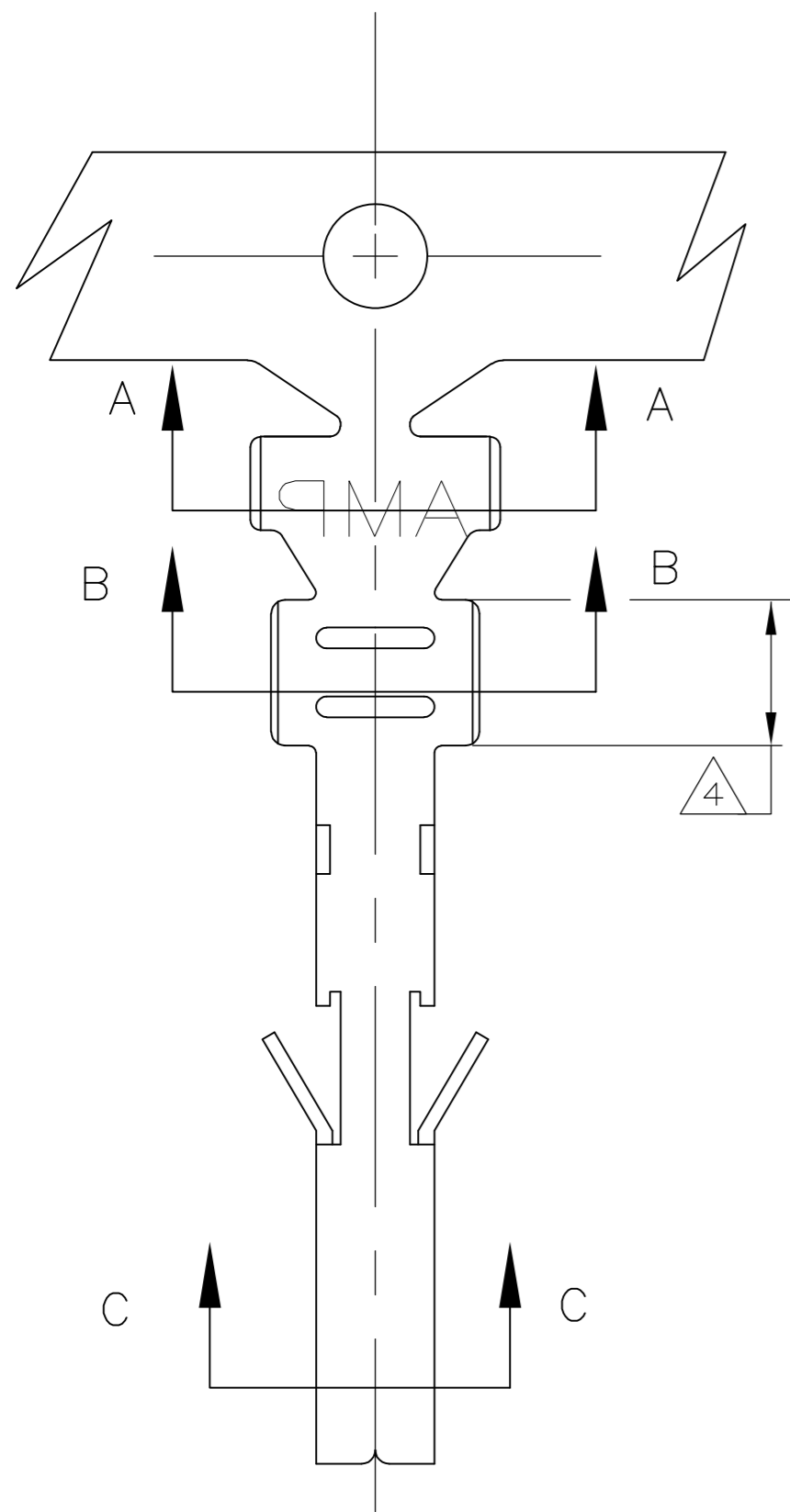
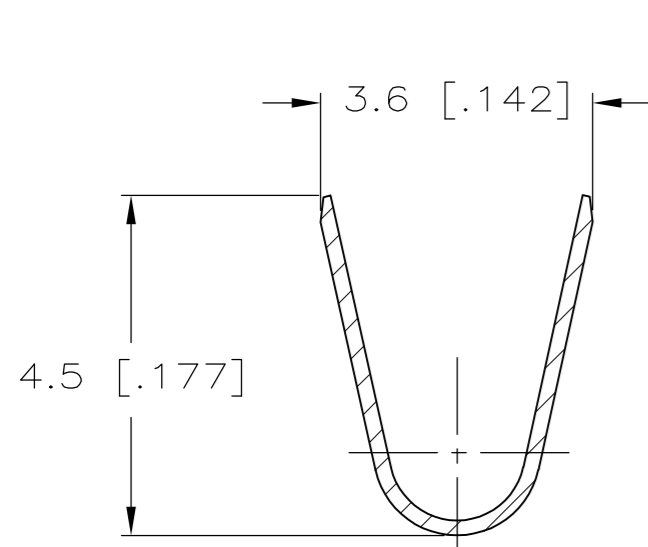

SECTION A-A

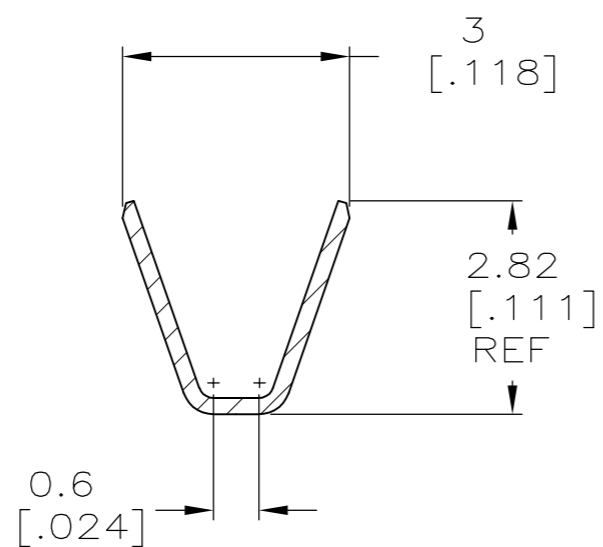

SECTION B-B

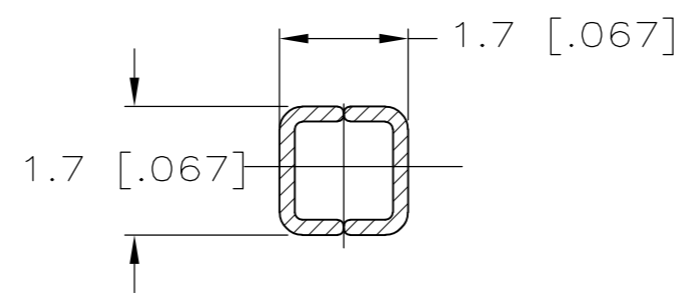

SECTION C-C

GOLD $\triangle 3 \triangle 4$	PHOS. BRZ.	1586055-4
PRE-TIN	PHOS. BRZ.	1586055-3
GOLD $\triangle 3 \triangle 4$	BRASS	1586055-2
PRE-TIN	BRASS	1586055-1
FINISH:	MATERIAL:	PART NO.

METRIC

THIS DRAWING IS A CONTROLLED DOCUMENT.		DWN S. HOOVER 15-NOV-2004	Tyco Electronics Corporation Harrisburg, PA 17105-3608	
DIMENSIONS: mm [INCHES]		CHK D. COLEY 15-NOV-2004	NAME	
TOLERANCES UNLESS OTHERWISE SPECIFIED:		APVD D. COLEY 15-NOV-2004	TERMINAL, SOCKET VAL-U-LOK(TM)	
0 PLC ±		PRODUCT SPEC	SIZE A2	CAGE CODE 00779
1 PLC ± 0.2 [.01]		APPLICATION SPEC	DRAWING NO C=1586055	RESTRICTED TO -
2 PLC ± 0.13 [.005]		WEIGHT	SCALE 10:1	SHEET 1 of 1
3 PLC ± 0.254 [.0100]		CUSTOMER DRAWING	REV C	
4 PLC ±				
ANGLES ±				
FINISH				